

# 18W Lite IIB Schematic

www.dockeryamps.com

April 29, 2008

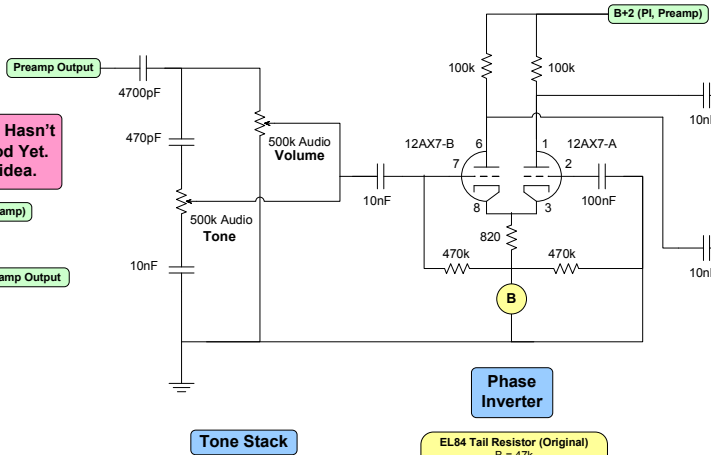
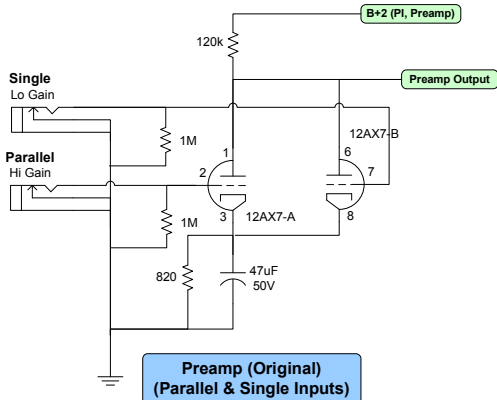
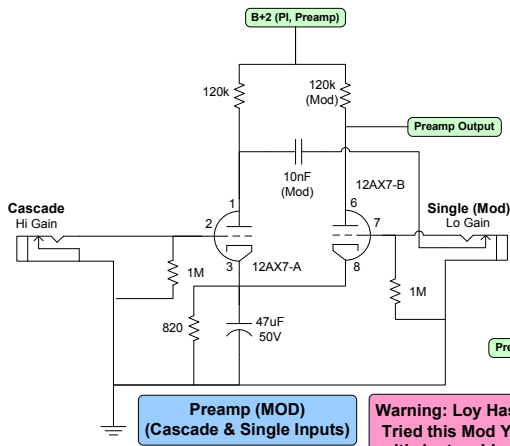

**EL84 Tail Resistor (Original)**  
B = 47k  
**6V6 Tail Resistor (Mod)**  
B = 22k  
**6V6 and EL84 Tail Resistor (Mod)**  
B = 47k

**EL84 Bias (Original)**  
A = 150 5W  
**6V6 Bias (Mod)**  
A = 250 5W  
**6V6 & EL84 Bias (Mod)**  
A = 250 5W

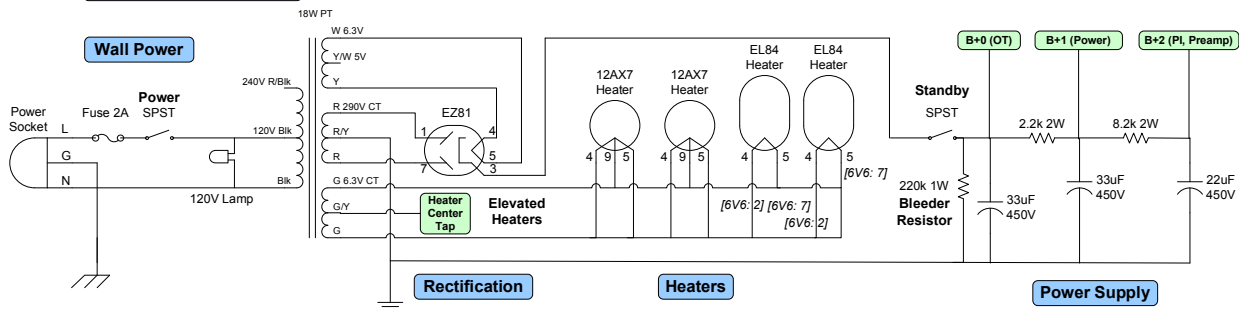
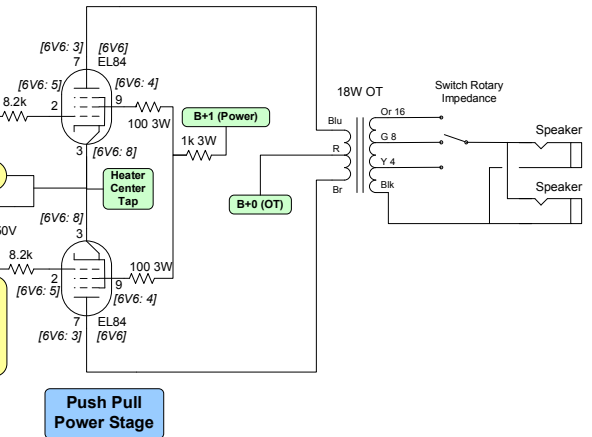

**6V6 / EL84 Output Section Notes**

- The layout is wired to enable switching between EL84s and 6V6s by just plugging in either 2 EL84s or 2 6V6s
- Do NOT put both EL84s and 6V6s in at the same time, put only one set in at a time
- If you want to have only EL84s wired up or only 6V6s wired up you can use this pin equivalency chart to wire accordingly

**Pin Equivalency Chart**

- Pin 3 EL84 = Pin 8 6V6 = Cathode
- Pin 9 EL84 = Pin 4 6V6 = Screen
- Pin 7 EL84 = Pin 3 6V6 = Plate
- Pin 2 EL84 = Pin 5 6V6 = Grid
- Pin 4 & 5 EL84 = Pin 2 & 7 6V6 = Heaters